

Design and Implementation of Cascaded Multilevel Inverter for The Grid Integrated Battery Energy Systems with ANN Intelligent Technique

**Ramesh Jatoth¹, Valloju Shiva Shankar²,
Keerthi Venkata Shiva Kumar³, Kummari Ganesh⁴**

¹Assistant Professor, Dept. of EEE, Methodist College of Engineering and Technology, Hyderabad

^{2,3,4}BE, IV Year, Dept. of EEE, Methodist College of Engineering and Technology, Hyderabad

Abstract

The increasing demand for efficient and reliable energy conversion systems has led to significant interest in multilevel inverter technologies for grid-connected energy storage systems. This paper presents the design and simulation of a control cascaded multilevel inverter for grid integrated battery energy systems. The proposed system utilizes a cascaded H-bridge multilevel inverter topology to convert DC power from battery energy storage into high-quality AC power suitable for grid integration. The cascaded multilevel inverter offers several advantages such as reduced harmonic distortion, improved output voltage quality, lower switching losses, and modular structure compared to conventional two-level inverters. In this work, a suitable control strategy is implemented to regulate the inverter output voltage and maintain synchronization with the grid. The battery energy storage system is integrated to support grid power during peak demand and store excess energy during low demand conditions, improving overall grid stability and reliability. The system is modeled and simulated using MATLAB/Simulink to analyze performance parameters such as output voltage waveform, total harmonic distortion, and system stability. The simulation results demonstrate that the proposed cascaded multilevel inverter provides improved power quality and efficient energy conversion for grid-connected battery systems. The proposed control method ensures stable operation, proper voltage regulation, and reduced harmonic content, making the system suitable for renewable energy and smart grid applications. The overall system improves energy management, grid reliability, and power quality, which are essential for modern power systems.

Keywords: Cascaded Multilevel Inverter Grid Integration, Battery Energy Storage System Harmonic Reduction, Power Quality

1. Introduction

In recent years, the demand for electrical energy has increased significantly due to rapid industrialization, population growth, urban expansion, and technological development across the world. Modern

industries, commercial infrastructures, and residential areas require uninterrupted and high-quality electrical power for efficient operation of electrical and electronic equipment. Conventional power generation systems mainly depend on fossil fuels such as coal, oil, and natural gas, which are limited in availability and cause environmental pollution, global warming, and greenhouse gas emissions. Due to these environmental and energy-related challenges, there is a growing need to develop sustainable energy solutions that can support the increasing power demand while reducing environmental impact. Renewable energy sources such as solar, wind, and hydro power are becoming important alternatives to conventional energy sources. However, renewable energy sources are intermittent in nature, which means energy storage systems are required to store excess energy and supply power when generation is low or demand is high[1], [2].

Battery Energy Storage Systems (BESS) play an important role in modern power systems by storing electrical energy and supplying it when required. Battery energy storage systems help in peak load management, voltage regulation, frequency control, and improving grid reliability and stability. In grid integrated battery energy systems, batteries store energy during low demand or excess generation periods and supply energy back to the grid during peak demand periods. This improves the efficiency of the power system and reduces stress on power generation units. Battery energy storage systems are widely used in renewable energy systems, electric vehicles, smart grids, uninterrupted power supply systems, and microgrid applications. However, to integrate battery energy storage systems with the electrical grid, efficient power electronic converters are required to convert DC power from batteries into AC power suitable for grid connection[3], [4].

Power electronic converters are essential components in grid-connected battery energy storage systems because they control the flow of electrical power between the battery and the grid. Among various power electronic converters, inverters are widely used to convert DC power into AC power. Traditional two-level inverters are commonly used for DC to AC conversion due to their simple design and low cost. However, conventional inverters produce square wave or quasi-square wave output voltage, which contains high harmonic distortion. High harmonic distortion affects power quality, causes overheating in electrical equipment, increases losses, and reduces system efficiency. To reduce harmonic distortion, filters are used at the output of the inverter, but large filters increase system cost, size, and complexity. Therefore, advanced inverter topologies are required to improve output voltage waveform and reduce harmonic distortion[5], [6].

Multilevel inverter technology has emerged as an effective solution for medium and high power applications. Multilevel inverters generate output voltage in multiple steps, producing a staircase waveform that closely resembles a sinusoidal waveform. Because of this stepped waveform, harmonic distortion is reduced and output voltage quality is improved. Multilevel inverters also reduce switching losses, electromagnetic interference, and stress on power electronic switches. Due to these advantages, multilevel inverters are widely used in renewable energy systems, motor drives, electric vehicles, FACTS devices, and grid-connected power systems. Multilevel inverters are particularly suitable for grid integrated battery energy storage systems because they can handle high voltage and high power applications efficiently[7], [8].

There are three main types of multilevel inverter topologies: diode-clamped multilevel inverter, flying capacitor multilevel inverter, and cascaded H-bridge multilevel inverter. The diode-clamped multilevel inverter uses clamping diodes to produce multiple voltage levels, while the flying capacitor multilevel inverter uses capacitors to generate stepped voltage levels. The cascaded H-bridge multilevel inverter consists of multiple H-bridge inverter units connected in series, each supplied by a separate DC source. Among these topologies, the cascaded H-bridge multilevel inverter is widely preferred due to its modular structure, simple design, reduced component count, and ability to use separate DC sources such as batteries or solar panels. The modular structure makes the cascaded multilevel inverter highly flexible and suitable for battery energy storage applications[9], [10].

In a cascaded H-bridge multilevel inverter, each H-bridge inverter produces three voltage levels: positive voltage, zero voltage, and negative voltage. By connecting multiple H-bridge inverters in series, multiple voltage levels can be generated at the output. The number of voltage levels depends on the number of H-bridge cells used in the inverter. As the number of voltage levels increases, the output waveform becomes closer to a sinusoidal waveform, which reduces harmonic distortion and improves power quality. Cascaded multilevel inverters also reduce voltage stress on switches and improve overall system efficiency. These advantages make cascaded multilevel inverters suitable for grid-connected battery energy storage systems[11], [12].

For grid integration, the inverter must operate in synchronization with the grid voltage and frequency. The inverter should supply power to the grid with controlled voltage magnitude, frequency, and phase angle. Proper control strategies are required to control the switching of power electronic devices in the inverter. The control system ensures proper voltage regulation, harmonic reduction, power flow control, and stable operation of the system. Various control techniques such as Pulse Width Modulation (PWM), Sinusoidal PWM, Space Vector PWM, and intelligent control techniques are used for controlling multilevel inverters. The selection of control technique affects the performance of the inverter in terms of harmonic distortion, switching losses, and efficiency[13], [14].

In grid integrated battery energy systems, the inverter also controls the charging and discharging of the battery depending on grid demand and battery state of charge. During peak load conditions, the battery supplies power to the grid, and during low load conditions, the battery stores energy from the grid or renewable energy sources. This bidirectional power flow requires proper control of the inverter to ensure stable and efficient operation. The control system also protects the battery from overcharging and deep discharging, which increases battery life and system reliability. Therefore, control of cascaded multilevel inverter plays a very important role in grid integrated battery energy systems[15], [16].

Simulation and modeling are important steps in the design and analysis of power electronic systems before practical implementation. MATLAB/Simulink is widely used for modeling and simulation of power electronic converters, inverters, and control systems. Simulation helps in analyzing output voltage waveform, harmonic distortion, switching performance, and overall system behavior under different operating conditions. By simulating the cascaded multilevel inverter with control strategy, system performance can be evaluated and optimized before hardware implementation. Simulation also reduces cost, time, and design errors in the development process[17], [18].

In this project, the design and simulation of a control cascaded multilevel inverter for grid integrated battery energy systems is presented. The proposed system converts DC power from battery energy storage into AC power suitable for grid integration using a cascaded H-bridge multilevel inverter. A suitable control strategy is implemented to control inverter output voltage and synchronize with the grid. The system is modeled and simulated to analyze output voltage waveform, harmonic distortion, and system performance. The proposed system improves power quality, reduces harmonic distortion, and enhances grid stability. Therefore, the control cascaded multilevel inverter is an effective solution for grid integrated battery energy storage systems and modern smart grid applications[19], [20].

2. Methodology

2.1 Importance of Multilevel Inverter

The multilevel inverter is an important component in grid integrated battery energy systems because it improves power quality, reduces harmonic distortion, and increases overall system efficiency compared to conventional two-level inverters. Conventional inverters produce square wave output with high harmonic content, which requires large filters and reduces system performance, whereas multilevel inverters generate output voltage in multiple steps, producing a waveform that is very close to a sinusoidal waveform and significantly reducing Total Harmonic Distortion (THD). Multilevel inverters are also suitable for high voltage and high power applications because the voltage stress is shared among multiple switches, which reduces switching losses and improves reliability. Another important advantage of multilevel inverters is their modular structure, especially in cascaded H-bridge topology, where multiple H-bridge units are connected in series and powered by separate DC sources such as batteries, making the system suitable for battery energy storage applications. Multilevel inverters also reduce electromagnetic interference, improve efficiency, and provide better voltage regulation and grid synchronization in grid-connected systems. Due to advantages such as reduced harmonics, improved power quality, lower switching losses, modular design, and suitability for battery energy storage systems, multilevel inverters are widely used in renewable energy systems, smart grids, and grid integrated battery energy systems, making them an essential part of the proposed system design and simulation.

2.2 Cascaded Multilevel Inverter

The cascaded multilevel inverter is one of the most important multilevel inverter topologies used in grid integrated battery energy systems due to its modular structure, simple design, and ability to use separate DC sources such as batteries. A cascaded multilevel inverter consists of multiple H-bridge inverter units connected in series, where each H-bridge is powered by an independent DC source. Each H-bridge inverter can generate three voltage levels: positive voltage, zero voltage, and negative voltage. By connecting multiple H-bridge units in series, multiple voltage levels are produced at the output, resulting in a stepped waveform that closely resembles a sinusoidal waveform. This reduces Total Harmonic Distortion (THD), improves power quality, and reduces the need for large output filters. The cascaded structure also reduces voltage stress on switches, improves efficiency, and allows the system to operate at high voltage and high power levels. Another important advantage of cascaded multilevel inverters is their modularity and fault tolerance, as the system can continue operating even if one module fails. Due to advantages such as reduced harmonics, modular structure, high efficiency, reduced switching losses,

and suitability for battery energy storage systems, cascaded multilevel inverters are widely used in grid-connected systems, renewable energy systems, and smart grid applications, making them suitable for the proposed grid integrated battery energy system.

2.3 ANN Integrated Multilevel Inverter

The Artificial Neural Network (ANN) integrated multilevel inverter is an advanced control approach used to improve the performance, efficiency, and power quality of cascaded multilevel inverters in grid integrated battery energy systems. In conventional multilevel inverter systems, control techniques such as Sinusoidal Pulse Width Modulation (SPWM) are used to generate switching pulses, but these methods may not provide optimal performance under varying load and grid conditions. The ANN controller is an intelligent control technique that can learn system behavior, adapt to changing conditions, and generate optimized switching signals for the multilevel inverter. The ANN controller takes input parameters such as reference voltage, output voltage, error signal, and grid parameters, and produces appropriate control signals to regulate inverter output voltage and reduce harmonic distortion. By using ANN control, the Total Harmonic Distortion (THD) is reduced, output voltage waveform quality is improved, switching losses are minimized, and system stability is increased. The ANN integrated cascaded multilevel inverter also improves dynamic response, voltage regulation, and grid synchronization performance compared to conventional controllers. Due to advantages such as adaptive control, reduced harmonics, improved efficiency, fast response, and intelligent decision making, ANN integrated multilevel inverters are widely used in modern power electronics, renewable energy systems, and grid integrated battery energy storage systems.

2.4 ANN Integrated Multilevel Inverter with Solar PV

The ANN integrated multilevel inverter with Solar PV system is an advanced power conversion and control system used for efficient energy conversion, power quality improvement, and intelligent control in grid integrated renewable energy systems. In this system, the Solar Photovoltaic (PV) system generates DC power from solar energy, which can be stored in battery energy storage systems and then converted into AC power using a cascaded multilevel inverter for grid integration. The multilevel inverter converts the DC voltage into a stepped AC voltage waveform with reduced harmonic distortion and improved output voltage quality compared to conventional inverters. The Artificial Neural Network (ANN) controller is used to control the switching of the multilevel inverter by analyzing input parameters such as reference voltage, PV output voltage, grid voltage, error signals, and load conditions. The ANN controller learns the system behavior and generates optimized switching pulses, which helps in reducing Total Harmonic Distortion (THD), improving voltage regulation, and increasing system efficiency. The integration of ANN with multilevel inverter and Solar PV system improves dynamic response, power quality, grid synchronization, and overall system performance. This system is highly suitable for renewable energy applications, smart grids, and grid integrated battery energy storage systems because it provides intelligent control, efficient power conversion, reduced switching losses, and improved reliability of the power system.

3. Results

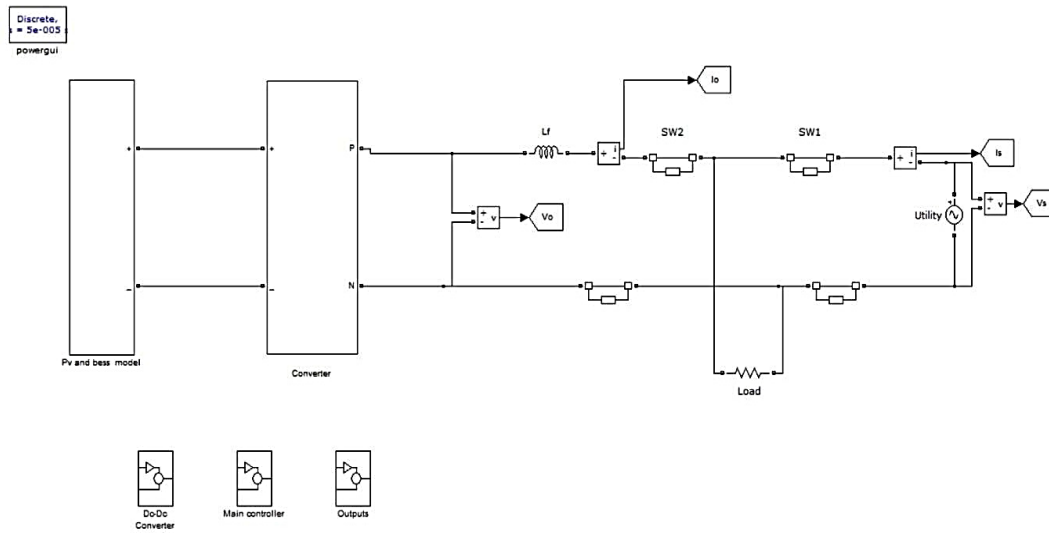

Figure 1 Proposed work

The proposed system consists of a Solar PV and Battery Energy Storage System connected to a grid through a controlled cascaded multilevel inverter system for efficient power conversion and grid integration. The solar PV system generates DC power, and the battery stores excess energy and supplies power when solar generation is low or load demand is high. The DC power from the PV and battery system is fed into a DC–DC converter, which regulates and maintains a constant DC voltage level. This regulated DC voltage is then supplied to the cascaded multilevel inverter, which converts the DC power into AC power with multiple voltage levels, producing a stepped waveform that reduces harmonic distortion and improves power quality. The inverter output is passed through an inductor filter to reduce harmonics and smooth the output current before supplying power to the load and utility grid. Switches are used to control power flow between the inverter, load, and grid, allowing the system to operate in grid-connected mode or standalone mode. Measurement blocks are used to measure output voltage, output current, grid voltage, and grid current for monitoring and control purposes. An Artificial Neural Network controller is used to generate switching pulses for the DC–DC converter and multilevel inverter based on reference voltage, output voltage, and error signals, which helps in reducing Total Harmonic Distortion, improving voltage regulation, maintaining grid synchronization, and improving overall system efficiency and performance.

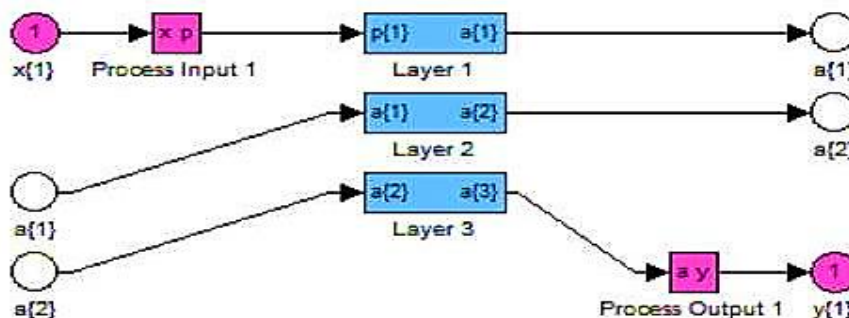

Figure 2 ANN controller

The Artificial Neural Network (ANN) controller is used in the proposed system to control the cascaded multilevel inverter and DC–DC converter for efficient power conversion and grid integration of the solar PV and battery energy storage system. The ANN controller acts as an intelligent control system that takes input parameters such as reference voltage, inverter output voltage, grid voltage, current, and error signals, and based on these inputs, it generates appropriate switching pulses for the multilevel inverter switches. The neural network is trained to minimize the error between reference voltage and actual output voltage, thereby improving voltage regulation and system stability. The ANN controller provides better performance compared to conventional controllers because it can adapt to changes in solar irradiance, load variations, and grid conditions. By using ANN control, the Total Harmonic Distortion is reduced, power quality is improved, switching losses are minimized, and dynamic response of the system is enhanced. The ANN controller also helps in maintaining grid synchronization, controlling power flow between solar PV, battery, load, and grid, and improving overall system efficiency and reliability, making it suitable for smart grid and renewable energy applications.

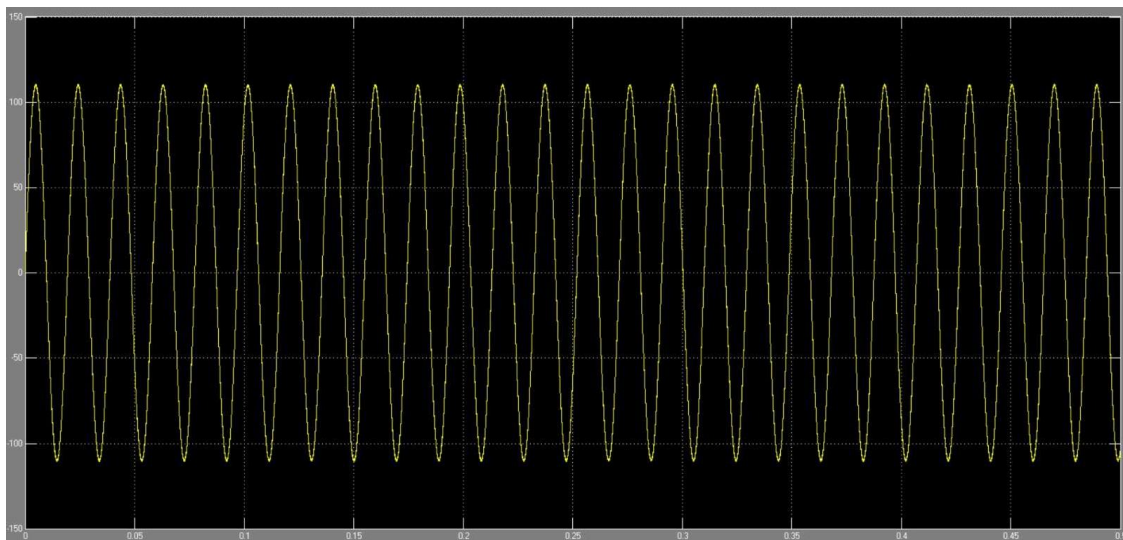

Figure 3 Grid output voltage

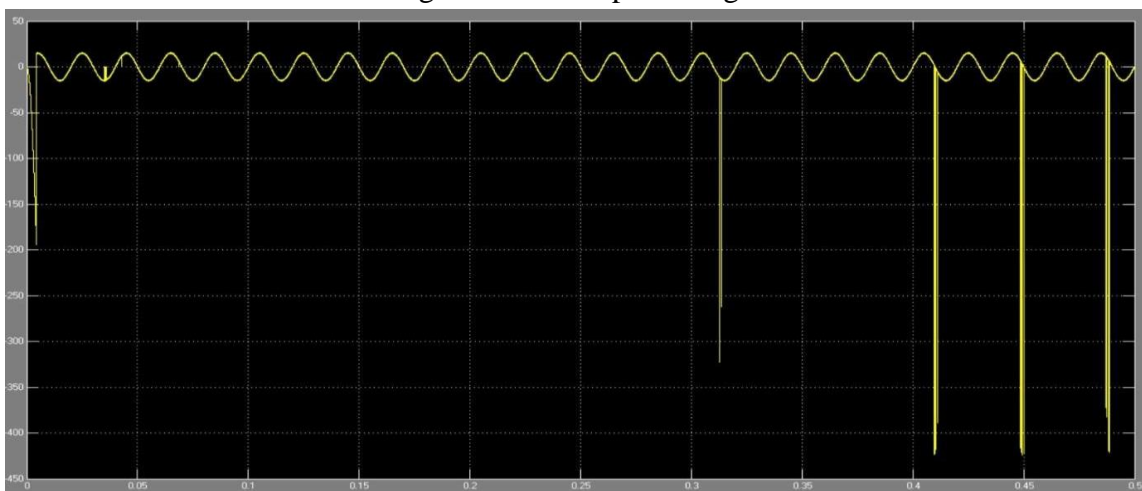

Figure 4 Inverter Output Current

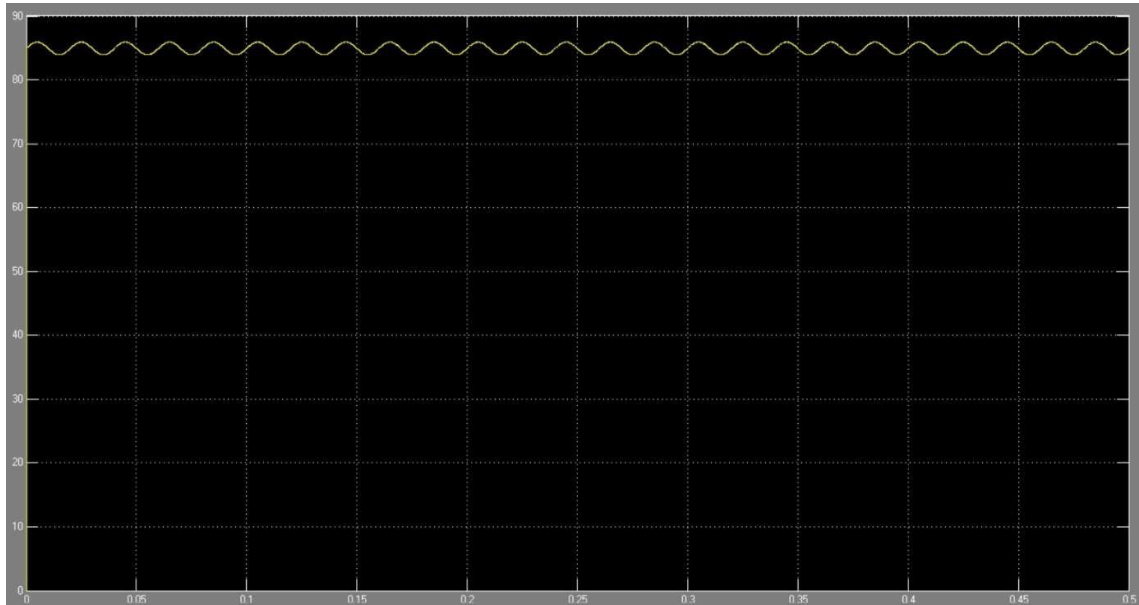

Figure 5 Voltage at Capacitor Vc2

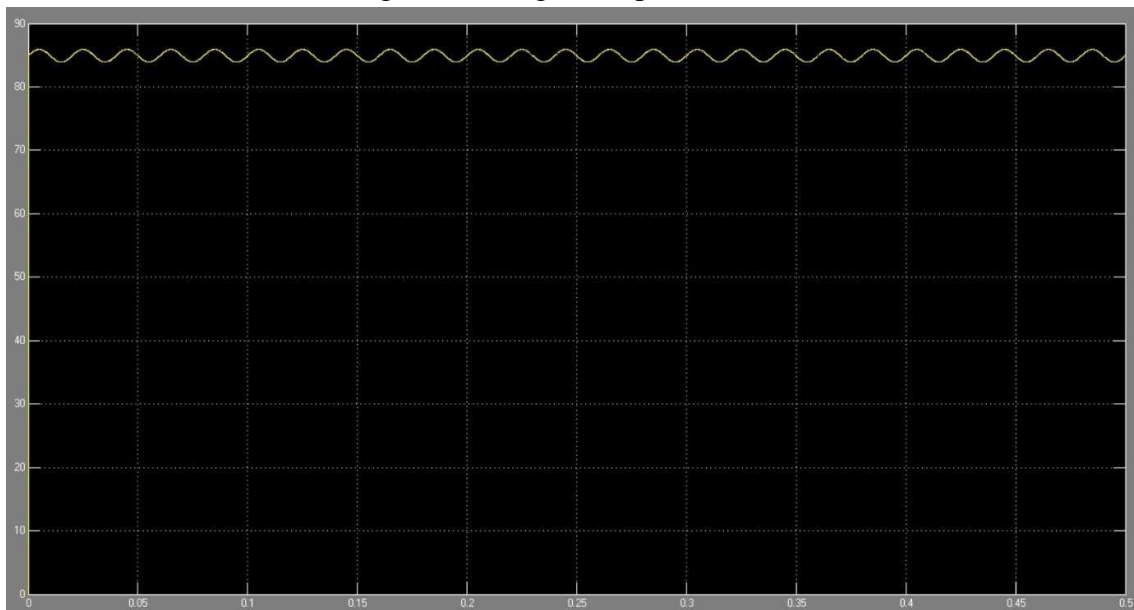

Figure 6 Voltage at Capacitor Vc3

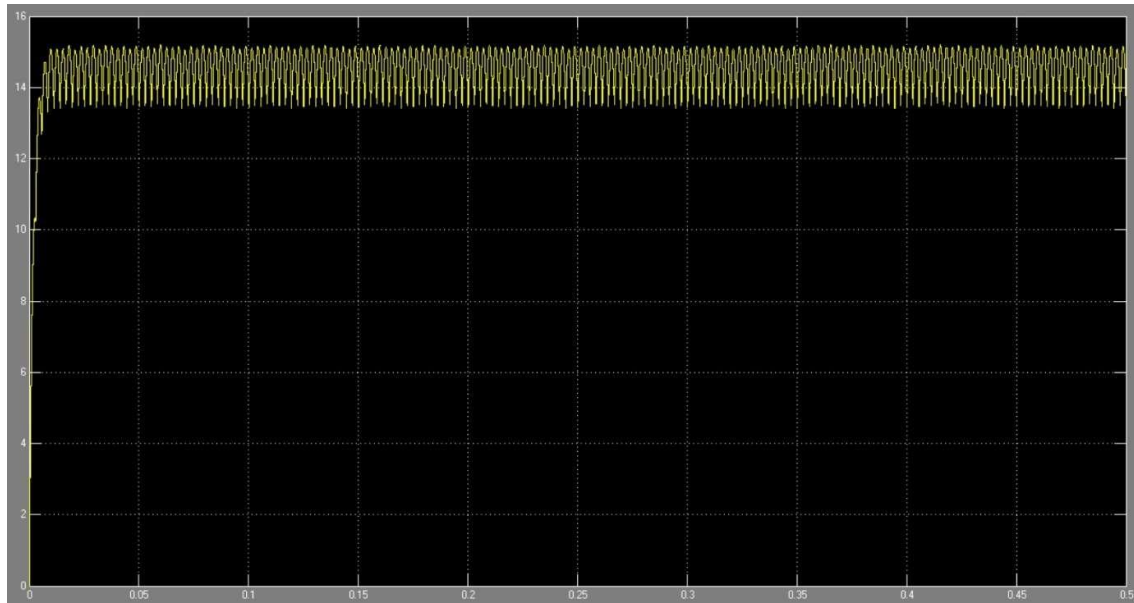

Figure 7 DC Current Idc

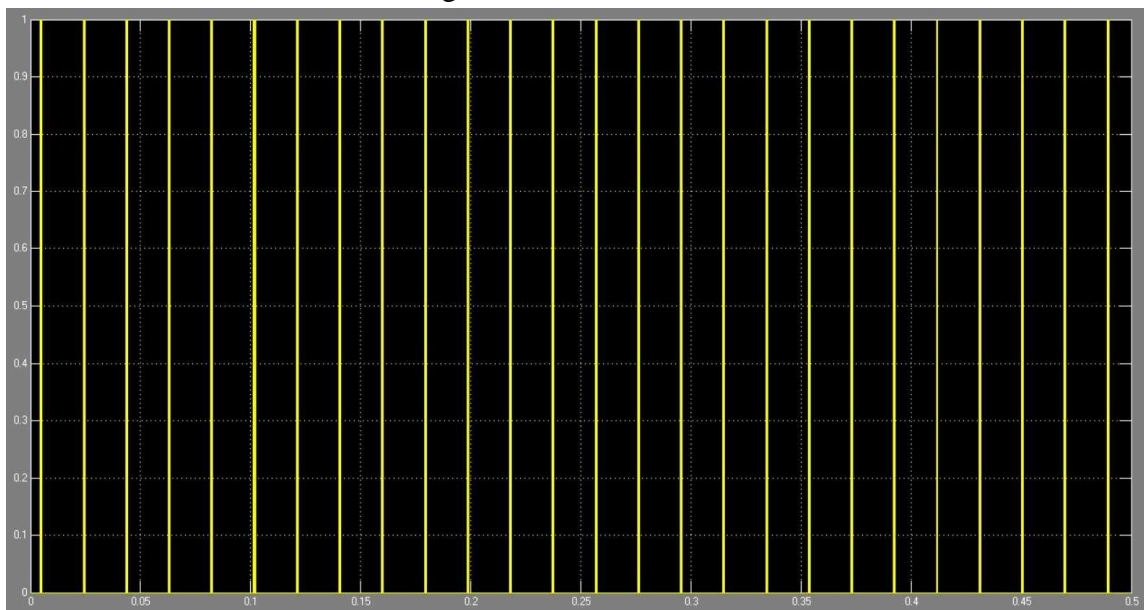

Figure 6 Top Switching Pattern S4

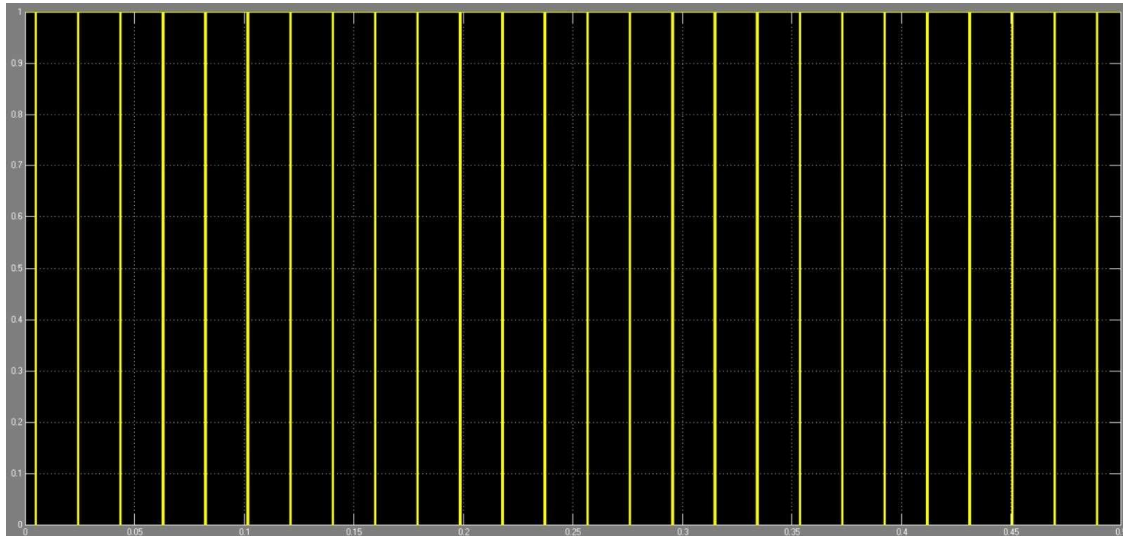

Figure 7 Low Switching Pattern S6

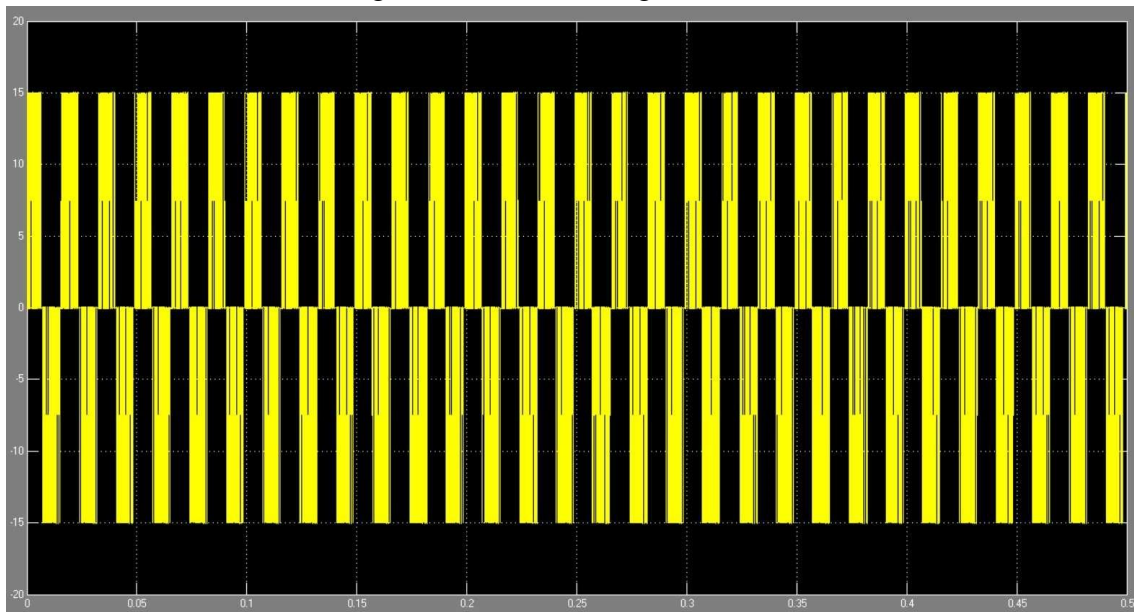

Figure 8 vdbc

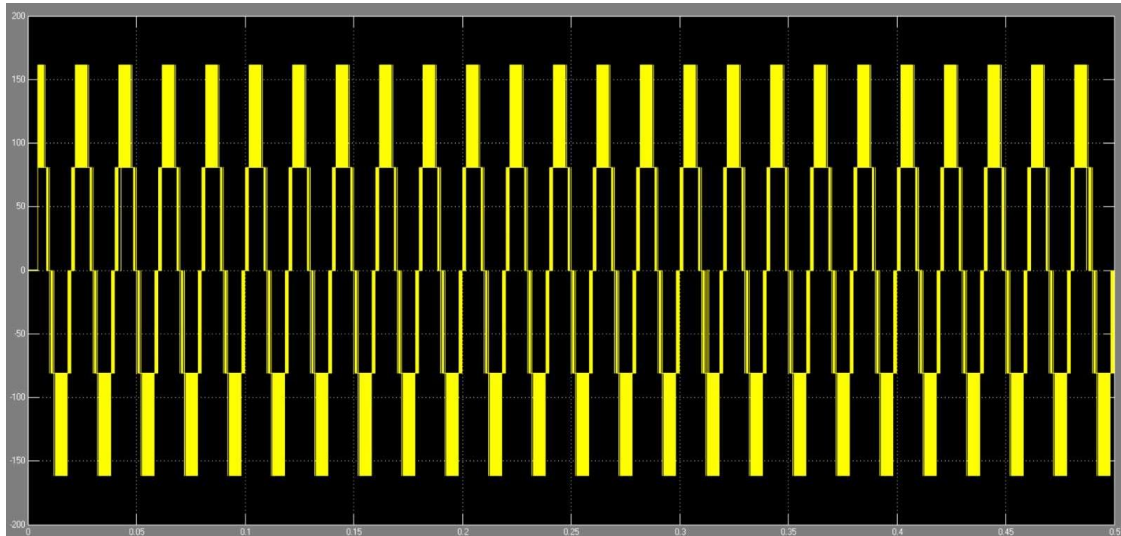

Figure 9 V_o

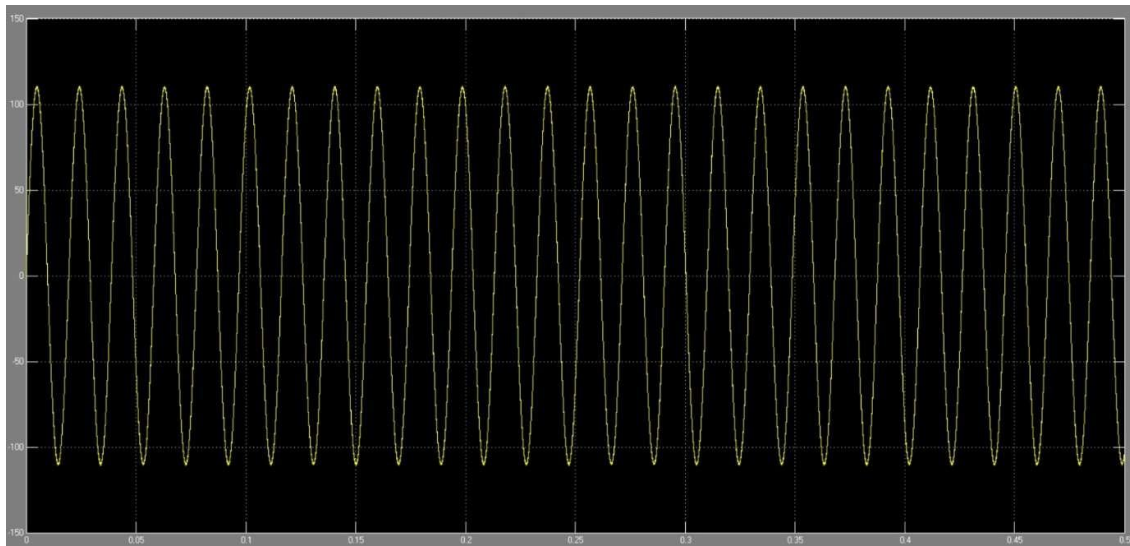

Figure 10 V_s

4. Conclusion

In this work, the design and simulation of a control cascaded multilevel inverter for a grid integrated battery energy system using Solar PV and an Artificial Neural Network controller has been successfully presented. The proposed system combines solar photovoltaic generation, battery energy storage system, DC–DC converter, cascaded multilevel inverter, and utility grid to achieve efficient power conversion and reliable energy management. The Solar PV system generates DC power, while the battery stores excess energy and supplies power during low generation or peak demand conditions, ensuring continuous power availability. The DC–DC converter regulates the varying DC voltage from the PV and battery system to provide a stable input to the inverter. The cascaded multilevel inverter converts the DC power into high-quality AC power with multiple voltage levels, resulting in reduced Total Harmonic Distortion, improved output voltage waveform, lower switching losses, and enhanced efficiency

compared to conventional inverters. The inclusion of an output filter further improves power quality before supplying power to the load and grid. The ANN controller plays a key role in generating optimized switching pulses by analyzing system parameters such as reference voltage, output voltage, and error signals, which leads to improved voltage regulation, fast dynamic response, reduced harmonics, and proper grid synchronization. The system is capable of operating in both grid connected and standalone modes, making it flexible and reliable under different operating conditions. Simulation results confirm that the proposed system provides improved power quality, efficient energy conversion, and stable performance. Therefore, the integration of Solar PV, battery energy storage, cascaded multilevel inverter, and ANN controller offers an effective solution for modern renewable energy systems, smart grids, and sustainable power applications.

5. Future Scope

The proposed ANN controlled cascaded multilevel inverter for grid integrated solar PV and battery energy storage systems can be further improved and extended in several ways to enhance its performance and practical applicability. In future work, the system can be implemented in real-time hardware using controllers such as DSP or FPGA to validate the simulation results under real operating conditions. The ANN controller can be enhanced by using advanced techniques such as deep learning and adaptive neural networks to improve accuracy, learning capability, and dynamic response under varying solar and load conditions. Integration of Maximum Power Point Tracking algorithms with the ANN controller can further increase the efficiency of the solar PV system by extracting maximum available power. The system can also be expanded to include hybrid renewable energy sources such as wind or fuel cells for improved reliability and continuous power supply. Additionally, higher level multilevel inverter configurations can be developed to further reduce harmonic distortion and improve power quality. Implementation of fault detection and protection mechanisms can increase system safety and reliability. Furthermore, integration with smart grid technologies and IoT-based monitoring systems can enable real-time control, data analysis, and efficient energy management. Hence, the proposed system has wide scope in renewable energy, microgrids, and smart grid applications.

References

1. N. Nireekshana, A. Archana, and K. Pullareddy, "A Classical H6 Topology for Modern PV Inverter Design," in *Power Energy and Secure Smart Technologies*, CRC Press, 2025, pp. 1–7. Accessed: Nov. 12, 2025. [Online]. Available: <https://www.taylorfrancis.com/chapters/edit/10.1201/9781003661917-1/classical-h6-topology-modern-pv-inverter-design-namburi-nireekshana-archana-pullareddy-kanth-rajini>
2. C. P. Prasad and N. Nireekshan, "A Higher Voltage Multilevel Inverter with Reduced Switches for Industrial Drive," *Int. J. Sci. Eng. Technol. Res. IJSETR*, vol. 5, no. 1, 2016, Accessed: Nov. 12, 2025. [Online]. Available: https://methodist.edu.in/web/uploads/naac/2019-11-19%2012_24_22pm%2092.pdf
3. N. Namburi Nireekshana and K. R. Kumar, "A Modern Distribution Power Flow Controller With A PID-Fuzzy Approach: Improves The Power Quality", Accessed: Nov. 12, 2025. [Online]. Available: https://www.academia.edu/download/112956747/ijeer_120124.pdf
4. N. Nireekshana, N. Ravi, and K. R. Kumar, "A Modern Distribution Power Flow Controller With A PID-Fuzzy Approach: Improves The Power Quality," *Int. J. Electr. Electron. Res.*, vol.

- 12, no. 1, pp. 167–171, 2024.
5. N. Nireekshana, R. Ramachandran, and G. V. Narayana, “A New Soft Computing Fuzzy Logic Frequency Regulation Scheme for Two Area Hybrid Power Systems,” *Int. J. Electr. Electron. Res.*, vol. 11, no. 3, pp. 705–710, 2023.
 6. N. Nireekshana, R. Ramachandran, and G. Narayana, “A Novel Swarm Approach for Regulating Load Frequency in Two-Area Energy Systems,” *Int J Electr Electron Res*, vol. 11, pp. 371–377, 2023.
 7. N. Nireekshana, R. Ramachandran, and G. V. Narayana, “A Peer Survey on Load Frequency Control in Isolated Power System with Novel Topologies,” *Int J Eng Adv Technol IJEAT*, vol. 11, no. 1, pp. 82–88, 2021.
 8. N. Nireekshana, “A POD Modulation Technique Based Transformer less HERIC Topology for PV Grid Tied-Inverter,” in *E3S Web of Conferences*, EDP Sciences, 2025, p. 01001. Accessed: Nov. 12, 2025. [Online]. Available: https://www.e3s-conferences.org/articles/e3sconf/abs/2025/16/e3sconf_icregcsd2025_01001/e3sconf_icregcsd2025_01001.html
 9. N. Nireekshana, K. P. Reddy, A. Archana, and P. R. Kanth, “Solar-Assisted Smart Driving System for Sustainable Transportation,” *Int. J. Innov. Sci. Res. Technol.*, vol. 10, no. 8, pp. 168–173, 2025.
 10. N. Nireekshana, M. A. Goud, R. B. Shankar, and G. N. S. Chandra, “Solar Powered Multipurpose Agriculture Robot,” *Int. J. Innov. Sci. Res. Technol.*, vol. 8, no. 5, p. 299, 2023.
 11. N. NIREEKSHANA, A. SHIVA, A. FURKHAN, M. SRIDHAR, A. OMPRAKASH, and K. K. SHIVA, “SIX PULSE TYPE SEGMENTED THYRISTOR CONTROLLED REACTOR WITH FIXED CAPACITOR FOR REACTIVE POWER COMPENSATION,” *Int. J.*, pp. 3153–3159, 2024.
 12. N. Nireekshana, “Reactive Power Compensation in High Power Applications by Bidirectional cascaded H-Bridge Based Statcom”, Accessed: Nov. 12, 2025. [Online]. Available: https://methodist.edu.in/web/uploads/naac/2019-11-19%2012_45_47pm%20152.pdf
 13. N. Nireekshana, G. M. Krishna, A. George Muller, K. Sai Manideep, and M. Abdul Mukheem, “Power Quality Improving using FCL and DVR,” *Int. J. Innov. Sci. Res. Technol. IJISRT*, pp. 624–632, May 2024, doi: 10.38124/ijisrt/IJISRT24MAY025.
 14. N. Nireekshana, R. Ramachandran, and G. V. Narayana, “Novel Intelligence ANFIS Technique for Two-Area Hybrid Power System’s Load Frequency Regulation,” in *E3S Web of Conferences*, EDP Sciences, 2024, p. 02005. Accessed: Nov. 12, 2025. [Online]. Available: https://www.e3s-conferences.org/articles/e3sconf/abs/2024/02/e3sconf_icregcsd2023_02005/e3sconf_icregcsd2023_02005.html
 15. B. Jula and N. Nireekshan, “Improving the Voltage Profile at Load End using DVR.,” *Grenze Int. J. Eng. Technol. GIJET*, vol. 4, no. 3, 2018, Accessed: Nov. 12, 2025. [Online]. Available: <https://search.ebscohost.com/login.aspx?direct=true&profile=ehost&scope=site&authtype=crawler&jrnl=23955287&AN=134178998&h=YQk2OkwoPFcVuqJX%2B1rKA0Mbu%2B3%2FNRI nXZhf6Wu1MJR4MoiWNdCgc7k4H5aV7e79V%2BdpemgvHWYJbJToV64CuQ%3D%3D&cr l=c>
 16. R. Jatoth and N. Nireekshana, “Improvement of Power Quality in Grid Connected Non



- Coventional Energy Sources at Distribution Loads,” *Grnze Int J Eng Technol GIJET*, vol. 4, no. 3, 2018, Accessed: Nov. 12, 2025. [Online]. Available:
https://methodist.edu.in/web/uploads/naac/2019-11-19%2012_58_06pm%20201.pdf
17. N. Nireekshana, S. Unissa, B. R. Jaleja, C. Mukta Tejaswi, P. Mangathayaru Mahitha, and P. Vaishnavi, “FACTS: Present and Future,” *Int. J. Innov. Sci. Res. Technol. IJISRT*, pp. 2350–2358, Oct. 2024, doi: 10.38124/ijisrt/IJISRT24SEP1424.
 18. N. Nireekshana, R. Ramachandran, and G. V. Narayana, “An innovative fuzzy logic frequency regulation strategy for two-area power systems,” *Int. J. Power Electron. Drive Syst. IJPEDS*, vol. 15, no. 1, pp. 603–610, 2024.
 19. Namburi Nireekshana, Tanvi H Nerlekar, P. N. Kumar, and M. M. Bajaber, “An Innovative Solar Based Robotic Floor Cleaner,” May 2023, doi: 10.5281/ZENODO.7918621.
 20. Namburi Nireekshana, A. Archana, Setla Manvitha, Mohammed Saad Ahmed, Nisar Ahmed Khan, and Akellu George Muller, “Unique Facts Device for Power Quality Mitigation,” Feb. 2024, doi: 10.5281/ZENODO.10652911.